

CV analyzer and Mercury Probe Setup.

1. Mercury Probe:

The figure below shows a picture of the mercury probe and the CV-analyzer. The mercury probe has three contacts. Two front contacts that are made by liquid mercury, and a back contact that is made by pushing a stainless steel cylinder against the wafer. The two front contacts are an inner dot (diameter = 775 μm) and an outer almost closed ring situated around the dot. A vacuum pump is used to push the mercury against the wafer. For a particular vacuum range the size of the dot contact is very well defined. The vacuum is made by a small pump (white). At the top of the pump you find a black pressure adjuster that can be used to change the vacuum pressure. Please DO not change the setting of this adjuster. If the vacuum becomes too large, mercury will be sucked into the vacuum pump, and if the vacuum is too small, the size of the mercury contacts will no longer be very well defined. The setting should be near the dot.

Working with mercury can be hazardous, so please check the provided materials data sheet before starting with your experiments. Furthermore also check the content of the provided spill kit. This kit contains various materials and utilities to be used when cleaning mercury spills. You **MUST** be familiar with the content of the materials data sheet and the content of the spill kit before you can use the Mercury Probe setup.

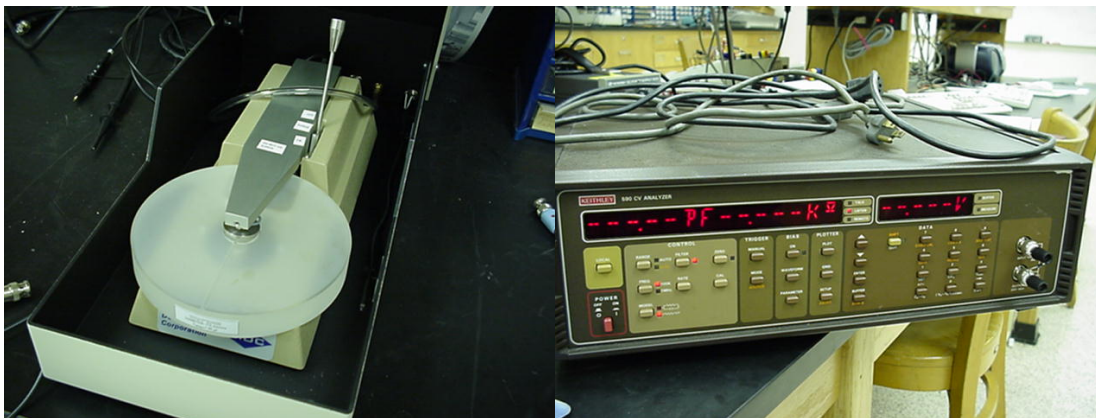

Fig. 1: Mercury Probe and CV analyzer.

Before loading your sample in the probe clean it and remove all silicon debris. Make sure that if you cleaned the sample by acetone that it is totally dry before it is loaded in the mercury probe. The material the mercury probe is made off does not like acetone or most of the other solvents. The wafer needs to be flipped so that the polished part of the wafer will make contact with the frosted glass substrate holder of the probe. After loading the wafer in the probe move the arm slowly from the off to the on position. This will push the mercury up against the wafer. This motion should not take more than 2.5 seconds. Figure 2 shows a line diagram of the mercury probe and explains what happens.

When removing the sample from the mercury probe do the same in reversed order. Move the arm slowly from the on to the off position. Make sure that the whole motion will take approximately 2.5 seconds. When you take your sample out of the probe be careful as

small mercury droplets might be attached to the wafer. We do not want those mercury droplets on the floor in the lab, so it is important to flip the wafer above the measurement system. If mercury droplets fall from the sample we would like the measurement enclosure to collect them. Make sure to remove any mercury from your sample, before you store it in the sample-box. Use the mercury absorbers provided in the spill kit. Use gloves under all circumstances.

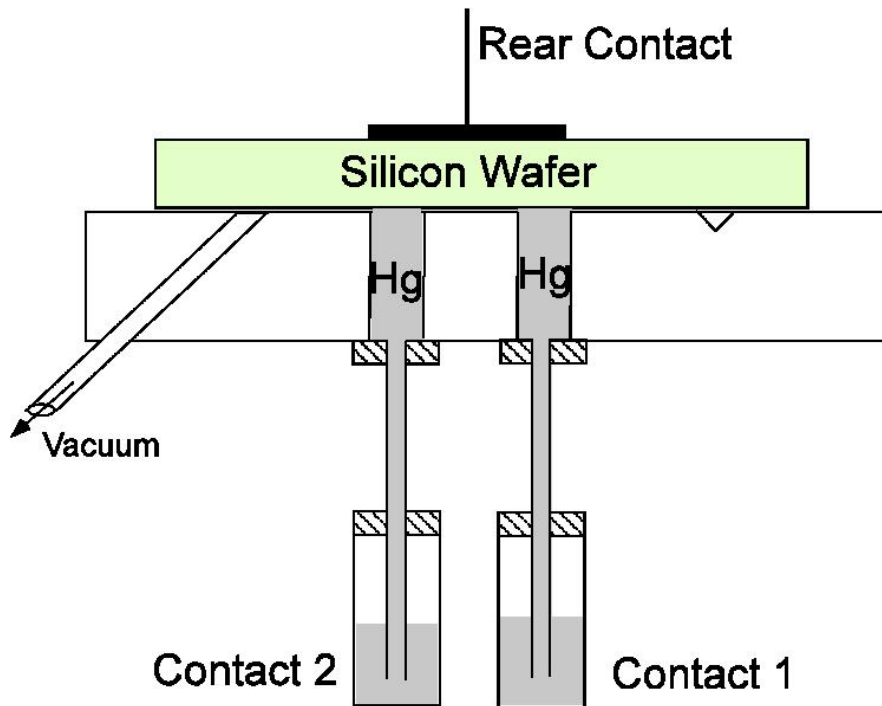

Fig. 2: Diagram of Mercury Probe.

2. Contacts:

When a metal and a semiconductor are brought together, two types of contacts may be formed, ohmic or rectifying. The specific nature of this contact is dictated by the relative work functions of the individual materials. Since mercury has a work-function of 4.53 eV, heavily doped n+ type silicon an effective workfunction of 4.0 eV, and heavily doped p+ type silicon an effective workfunction of 5.0 eV, mercury will make a rectifying contact to both n and p-type silicon. So there will be a Schottky barrier between the mercury and the silicon and the contact will only conduct current in one direction, with an I-V characteristic similar to that of a diode. Because of the rectifying nature of the mercury-silicon contact, the mercury probe is less suitable for classical two-point probe or four-point-probe measurements [1]. The technique is however very well suited to determine the quality of the oxide, the average carrier concentration, and the carrier concentration profile of the sample. More details on those techniques can be found in reference 2. In addition to the work-functions of the materials involved also the condition of the surface is important. Charge accumulated at the surface can cause band-bending and higher or lower the Schottky barrier. Because of this it is important to

prepare the surface before the measurement. P-type silicon should be freshly etched in buffered HF just prior to measurement. N-type silicon, however, makes a better junction if it has a thin oxide layer on it. Often the native oxide layer will suffice, or a thin oxide may be grown by boiling the sample in de-ionized water for a few minutes [3].

3. CV analyzer:

The block-diagram of the Keithley 590 CV analyzer is printed in Fig. 3. The system can be used to measure the real and the imaginary part of the impedance at two different frequencies (i.e. 100 kHz, and 1 MHz). The impedance is determined by applying an AC voltage of 15 mV to the sample and measuring the current that is in phase with the voltage and the current that is 90 degrees out of phase with the voltage.

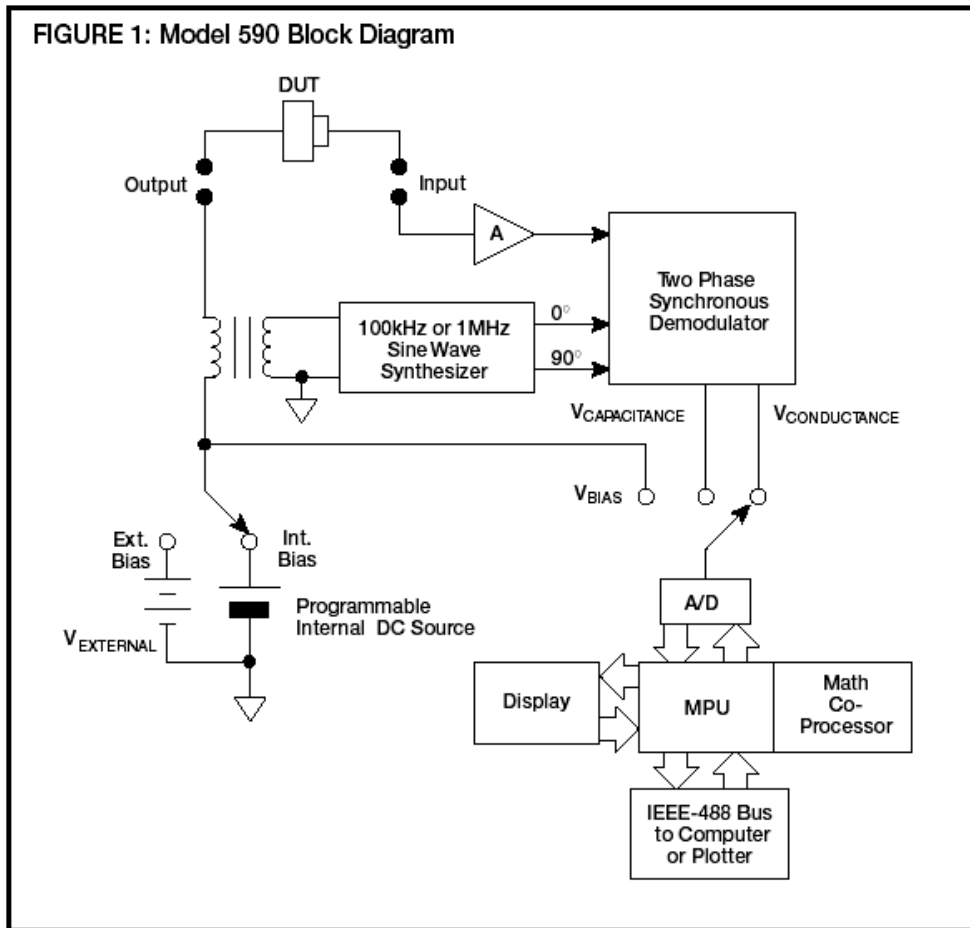

FIGURE 3: Model 590 Connection Correction Methods

If the device under test is a resistor and a capacitor in series, the computer in the CV-analyzer will convert the in-phase and out-phase amplitudes of the current into a resistance and a capacitance using the following calculation scheme:

$$\tilde{V} = \tilde{I}Z \Leftrightarrow Z = R - \frac{j}{\omega C} = \frac{\tilde{V}}{\tilde{I}} = \frac{15mV}{\tilde{I}_{real} + j\tilde{I}_{imaginary}} = \frac{15mV}{\tilde{I}_{real}^2 - \tilde{I}_{imaginary}^2} [\tilde{I}_{real} - j\tilde{I}_{imaginary}] \Leftrightarrow$$

$$R = \frac{15mV}{\tilde{I}_{real}^2 - \tilde{I}_{imaginary}^2} \tilde{I}_{real}$$

$$C = -\frac{\tilde{I}_{real}^2 - \tilde{I}_{imaginary}^2}{\omega \tilde{I}_{imaginary} 15mV}$$

The voltage is generated by the transformer. A transimpedance amplifier (A) converts the current flowing into the input in a voltage that is lead to a synchronous demodulator. This demodulator compares this “current-signal” with the applied voltage and measures the component of the current that is in phase with the applied voltage and the component of the current that is 90 degrees out of phase with the current.

It is also possible to put the CV-analyzer in the parallel mode. In that case the systems assumes that the device under test is a conductor and a capacitor that are connected parallel. In the parallel mode the relation between V, I_{real}, I_{imaginary}, 1/R, and C will be different.

A bias voltage can be applied to the device under test. The CV analyzer communicates with a computer via a GPIB interface board and the SCI graphical user interface. For more details on how to use this interface see the Computer-interface Manual of the semiconductor parameter analyzer. The Metrics software is not without bugs. Very often you need to remove the first or the last measurement points.

4. CV measurements on Si/SiO₂:

The figure below shows what happens to the capacitance if you apply a positive or a negative bias voltage p-type MOS structure.

A positive voltage applied to the mercury contact will cause inversion under the oxide. The material will become n-type. A small change of the mercury contact voltage, ΔV, will now cause a small change in the charge on the mercury contact, ΔQ⁺. ΔQ⁺=C*ΔV. The other plate of the capacitor is formed by the inversion/space charge region. The charge of this area can be changed in two ways:

1. In the space charge region electron hole pairs that are thermally generated will be separated by the internal electric field and will facilitate the AC-current through the capacitor structure. As the total number of electron hole pairs that are generated is limited the maximum AC-current density is limited to:

$$J_{SCR} = \frac{qn_i W}{\tau_g}$$

Where n_i is the intrinsic carrier concentration of undoped semiconductor material, W is the width of the space charge region, and τ_g is the generation life-time.

So using the I-V relation of a capacitor and some typical values for silicon, we find for the maximum dV/dt:

$$\frac{dV}{dt} \leq \frac{qn_i W}{\tau_g C_{ox}} \approx 0.5 \text{ V/s.}$$

If the voltage is changed faster than this, the scr generation current will not be able to facilitate the current through the oxide. So this process will only take place at relatively low frequencies (below 1 kHz). At low frequency, the measured capacitance will be equal to C_{ox} .

2. The total width of the space charge region can be increased. The larger electric field under the oxide will push or pull the positive hole-sea. This motion of the hole-sea will create a positive net charge at a distance W under the oxide. This process will even take place at higher frequencies. So at high frequencies the measured capacitance will be C_{ox} in series with C_{bulk} . Another way of seeing this is to realize that the effective distance between the positive and negative charges increase.

A negative voltage applied to the mercury contact will cause accumulation of holes under the oxide. It is clear from Fig. 3b that the measured capacitance will be equal to the C_{ox} .

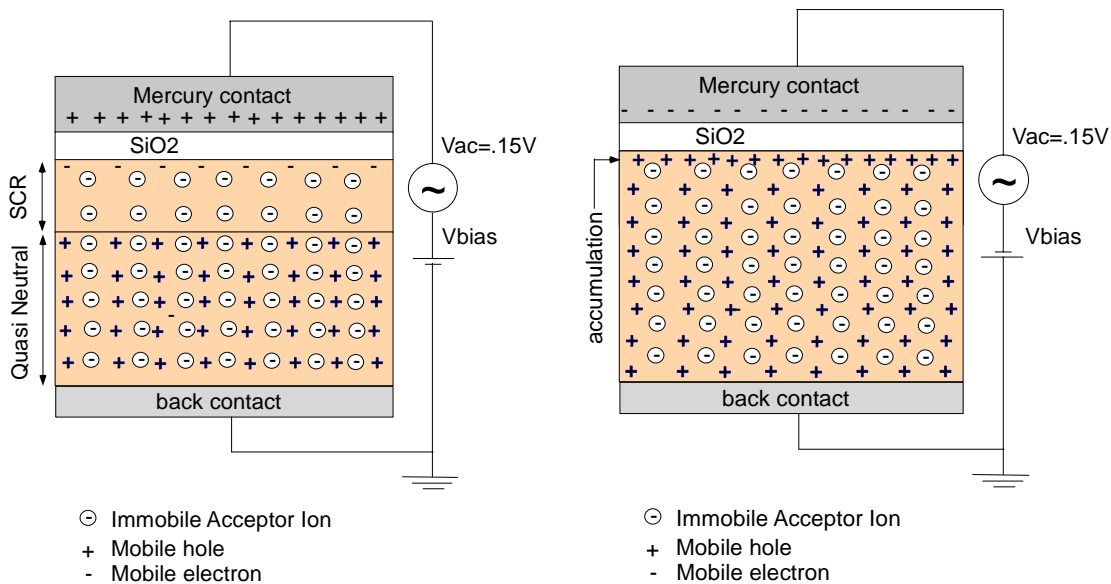

Fig. 4: p-type MOS structure with positive (a) and negative (b) bias voltage.

Make sure that if you do measurements on silicon that you do not check the pulse mode enabled box. Furthermore it is necessary to measure slowly and not to create sudden bias voltage changes larger than 0.5 volts/ second. The best results are obtained when starting in accumulation and then sweeping the voltage and slowly pushing the MOS structure in inversion (so scan from high C to low C values). If you start in inversion and you sweep to accumulation your curve will show some weird structure that we do not understand at the moment.

References:

[1] A Schottky contact will behave ohmic if the applied voltage is smaller than k_bT . A good value for silicon would be 5 mV. In that case it is possible to use a first order linear approximation for the exponential part of the I-V relation. It is not clear to me at this moment if mercury probes are used for classical two-point-probe or four-point-probe measurements.

[2] Dieter K. Schroder, "Semiconductor Material and Device Characterization", John Wiley and Sons, 1990, ISBN 0-471-51104-8.

[3] Operator's Manual Three function mercury probe, Materials Development Corporation, www.mdc4cv.com.